

VAR-OM35CustomBoard v2.3



CONTENT

PAGE NO.	SCHEMATIC PAGE
1	COVER PAGE
2	Block Diagram
3	SOM DIMM CONNECTOR
4	USB2.0 OTG ,HOST ,HUB
5	LCD, HDMI, TV OUT,LVDS,TOUCH
6	Audio, UART,Ethernet ,SDIO, GPIO
7	Extension connectors
8	Power

Disclaimer:

SchematicS are for reference only.
 Variscite LTD provides no warranty for the use of
 these schematics.
 Schematics are subject to change without notice.

Revision History

Rev 2.0	Added Features: 3 Port USB Composite Video Out VAR-SOM-37xx Support
Rev 2.0 A	VAR-SOM-37xx Assembly
Rev 2.0 B	VAR-SOM-35xx Assembly
Rev 2.1	VAR-SOM-AM35xx Assembly option
Rev 2.1 A	VAR-SOM-37xx Assembly
Rev 2.1 B	VAR-SOM-35xx Assembly
Rev 2.2	Adding GPIO level translator , Line in improvements
Rev 2.2 A	VAR-SOM-37xx Assembly
Rev 2.2 B	VAR-SOM-35xx Assembly
Rev 2.21	SD Card Connector change
Rev 2.3	Extension connectors part number change



Title 1. Cover			
Size A3	Document Number VAR-OM35CustomBoard v2.21	Project VAR-OM3XCustomBoard	Rev 2.3
Designer: Date:	<Designer> Thursday, August 18, 2011	Approved By: Sheet	<Approved By> 1 of 8

02 - Block Diagram

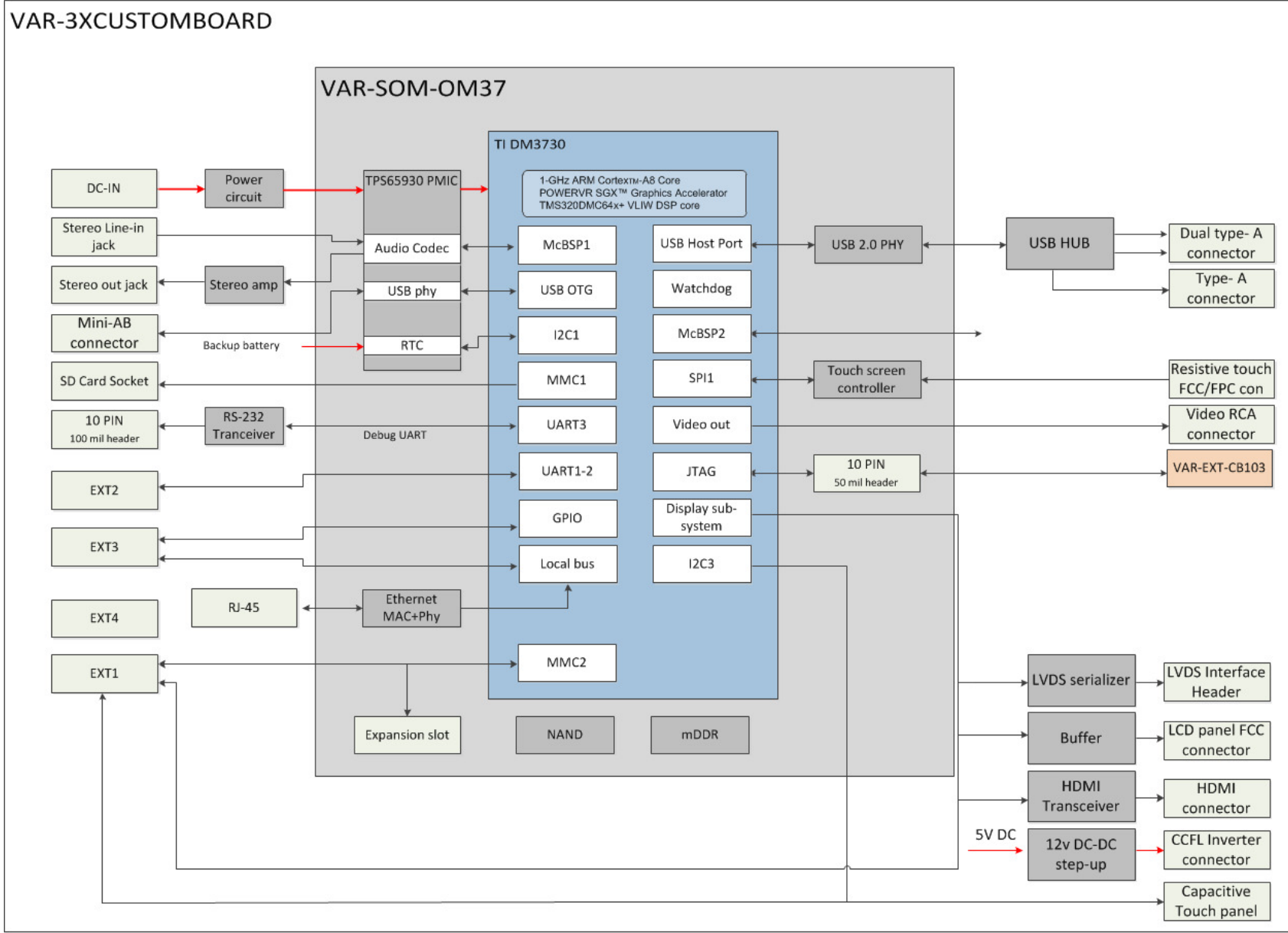

Title 2. Block Diagram			
Size A3	Document Number VAR-OM35CustomBoard v2.21	Project VAR-OM3XCustomBoard	Rev 2.3
Designer: Date:	<Designer> Thursday, August 18, 2011	Approved By: Sheet	<Approved By> 2 of 8

03 - VAR-SOM-OM3x Connector

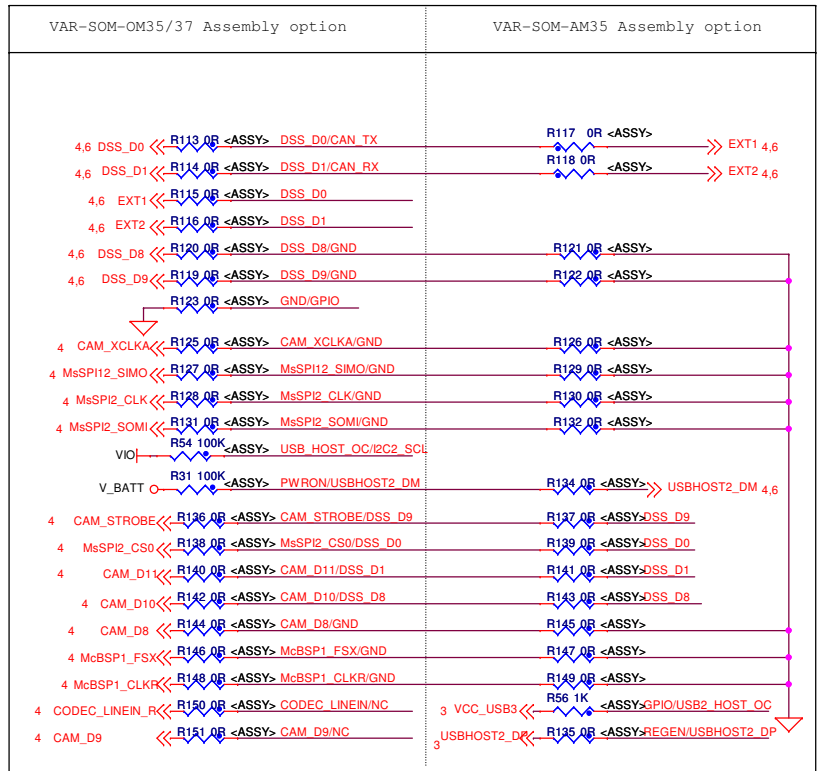
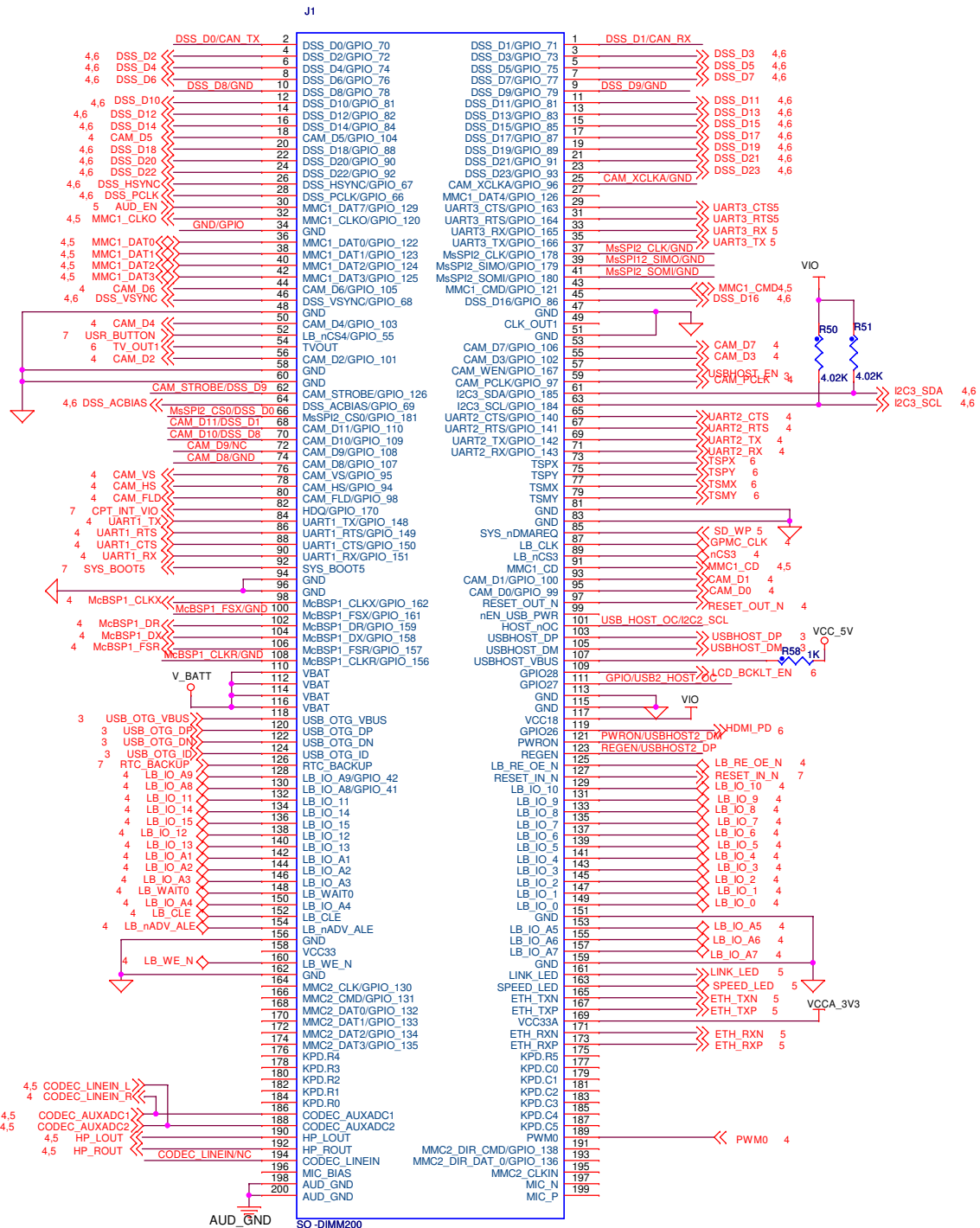



Title 03 - VAR-SOM-OM3x Connector			
Size A3	Document Number VAR-OM35CustomBoard v2.21	Project VAR-OM3XCustomBoard	Rev 2.3
Designer: <Designer>		Approved By: <Approved By>	
Date: Thursday, August 18, 2011		Sheet 3 of 8	

4. USB2.0 OTG ,HOST , HUB

USB PORT 1-2 : 2 x USB 2.0 Host - Dual Type A

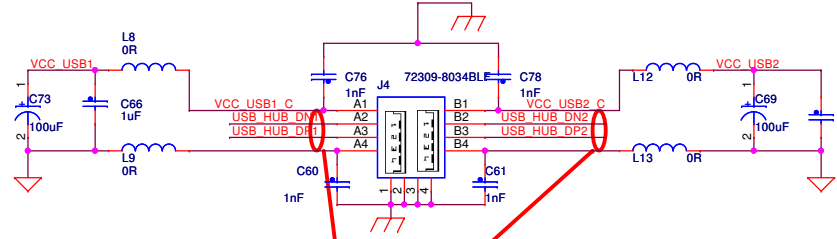

LAYOUT NOTE:
 USB 2.0 Differential Pair, annotated with a ring around the pair. Follow USB 2.0 routing guidelines.
 Length Match: +/- 100 mils
 Differential Impedance: 90 ohms

Power Distribution

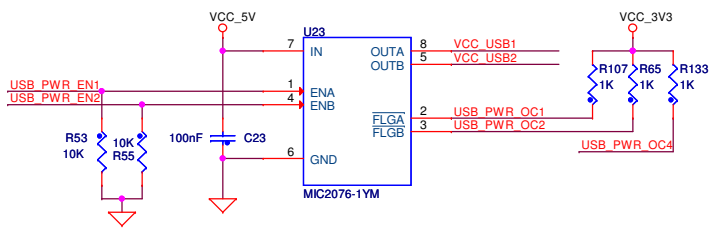

USB 2.0 OTG

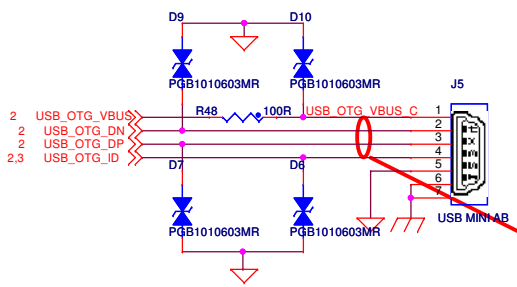

USB 2.0 PORT 3

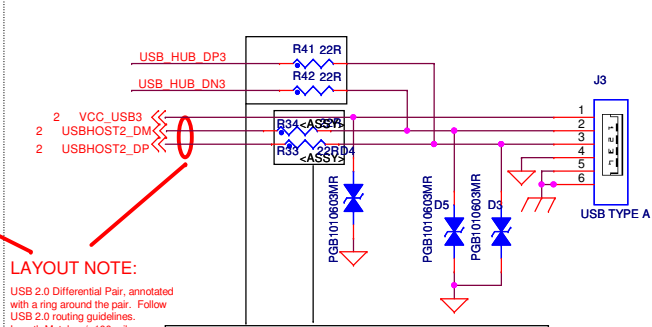

LAYOUT NOTE:
 USB 2.0 Differential Pair, annotated with a ring around the pair. Follow USB 2.0 routing guidelines.
 Length Match: +/- 100 mils
 Differential Impedance: 90 ohms

Assembly option:
 AM35xx dedicated USB HOST
 DM3730 USB hub port 3

Power Distribution

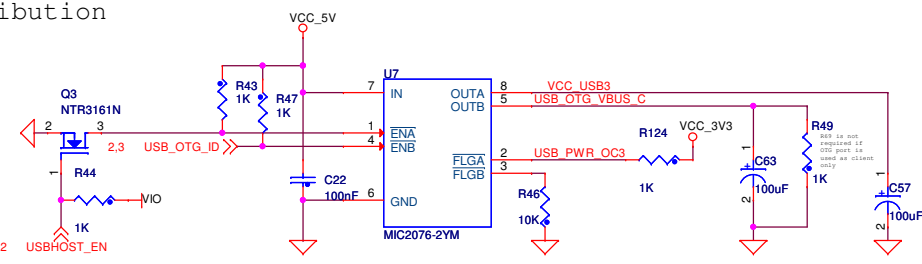

USB 2.0 HUB

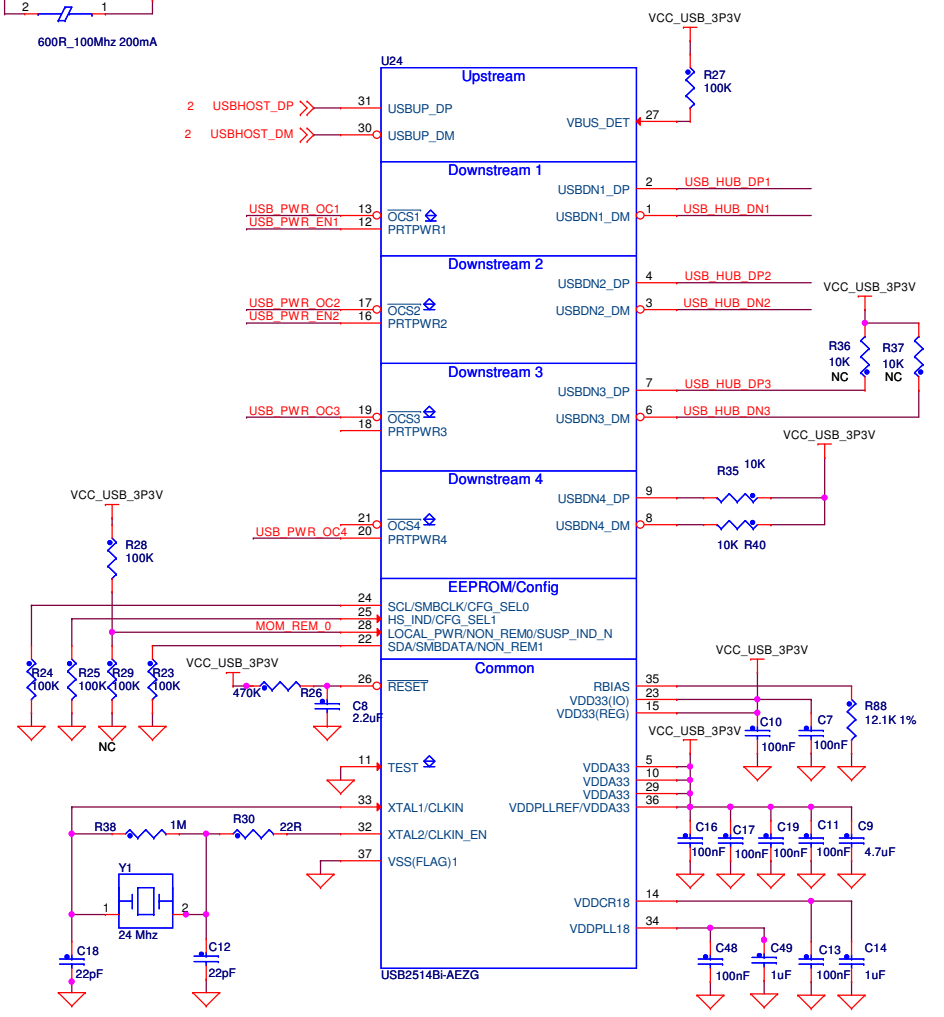
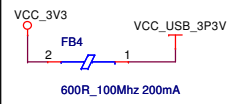

4. USB2.0 OTG ,HOST ,HUB			
File	Document Number	Project	Rev
A3	VAR-OM35CustomBoard v2.21	VAR-OM3XCustomBoard	2.3
Designer:	<Designer>	Approved By:	<Approved By>
Date:	Thursday, August 18, 2011	Sheet	4 of 8

5. LCD, HDMI, TV OUT, LVDS, TOUCH

24BIT LVDS serializer

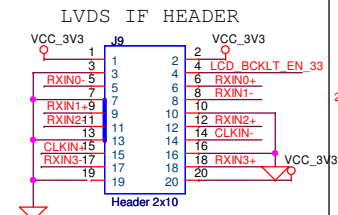
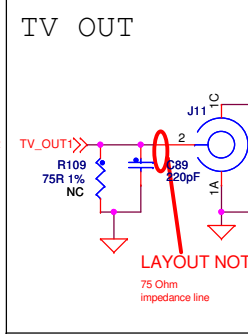
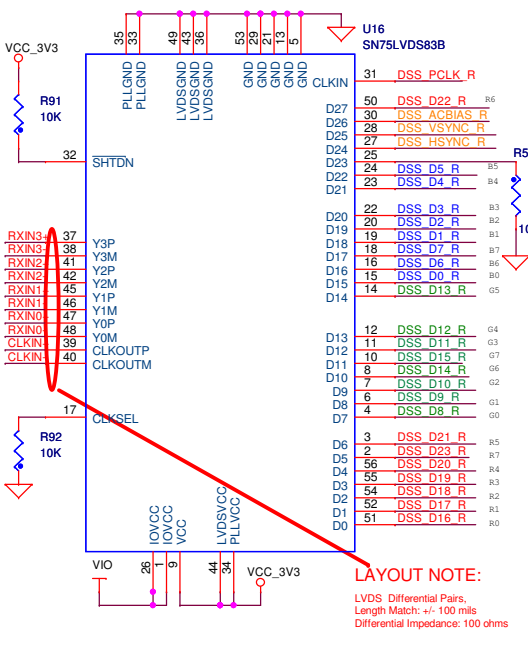

HDMI IF

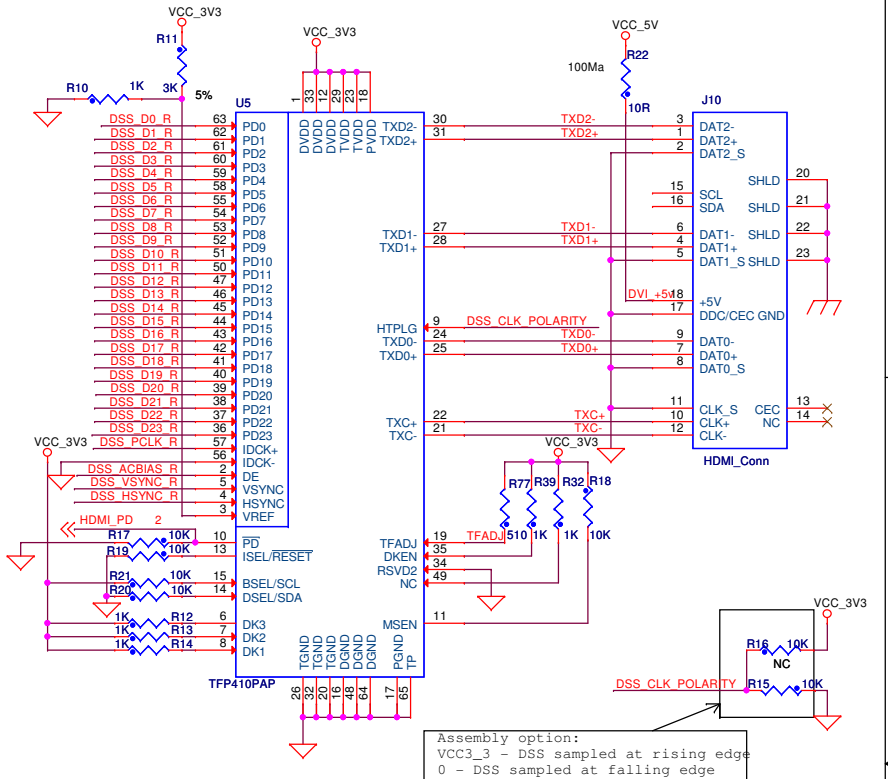
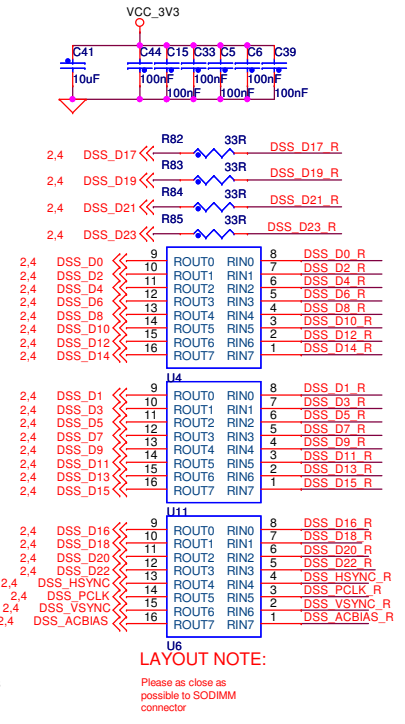

VIO --> 3.3V Level Translator

(Can be omitted in VAR-SOM-AM35 designs)

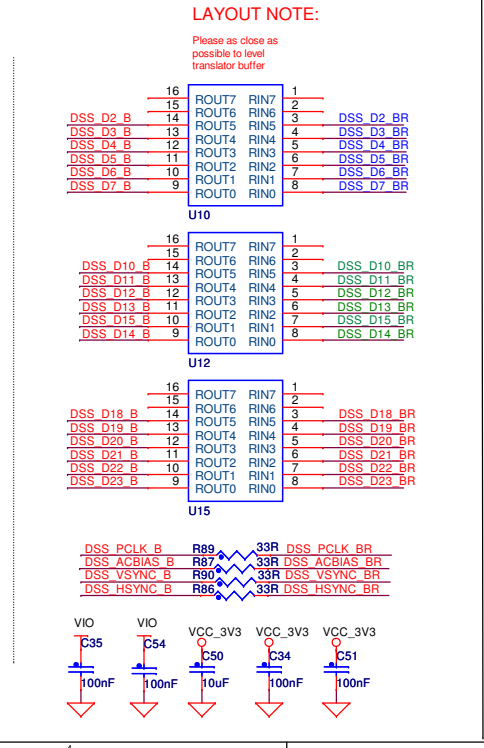
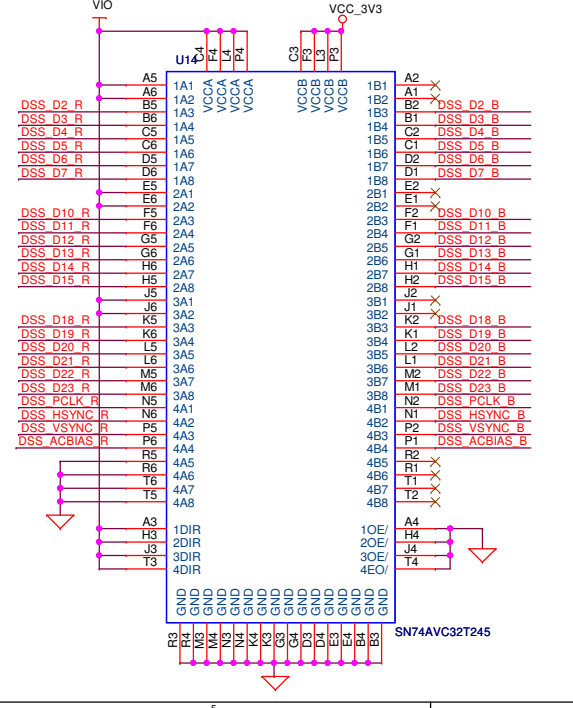

Parallel BUS FCC Connector

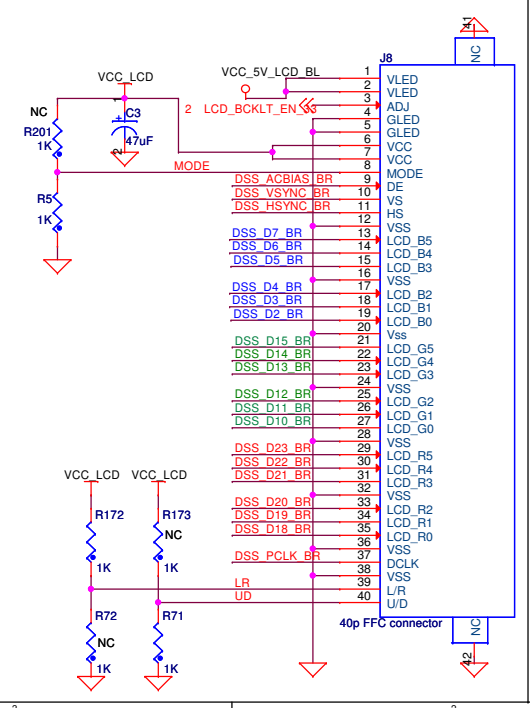

Touch Panel

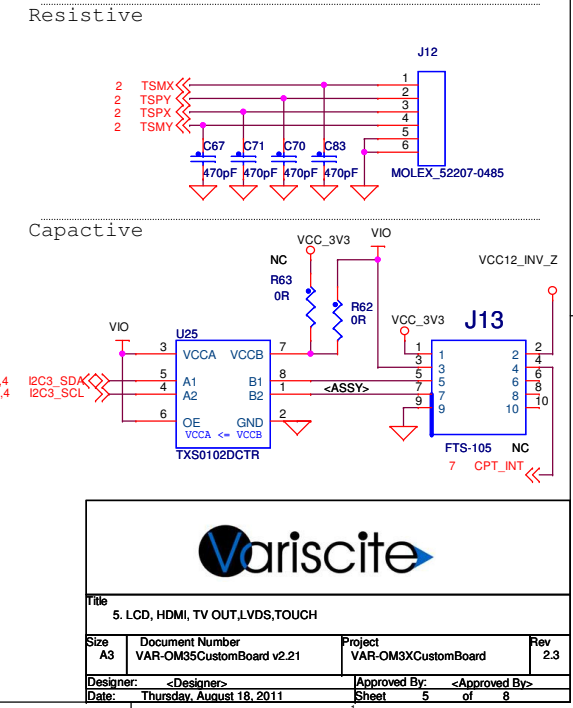

6. Audio / UART / Ethernet / SDIO / GPIO

Ethernet

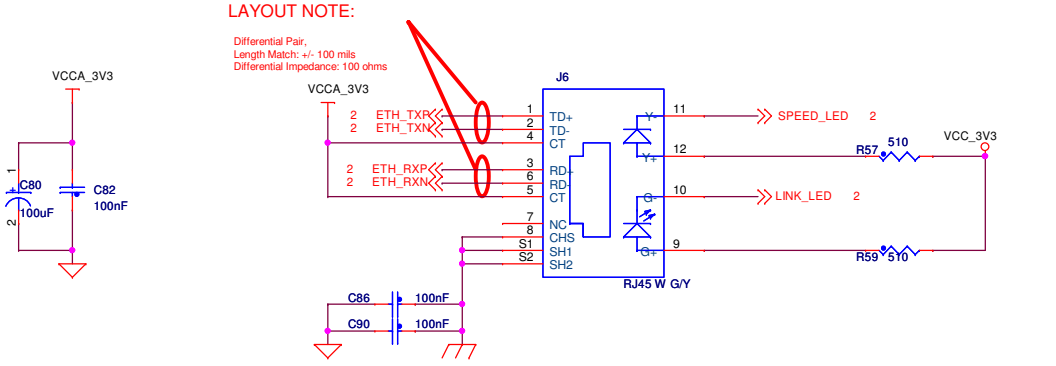

AUDIO IN

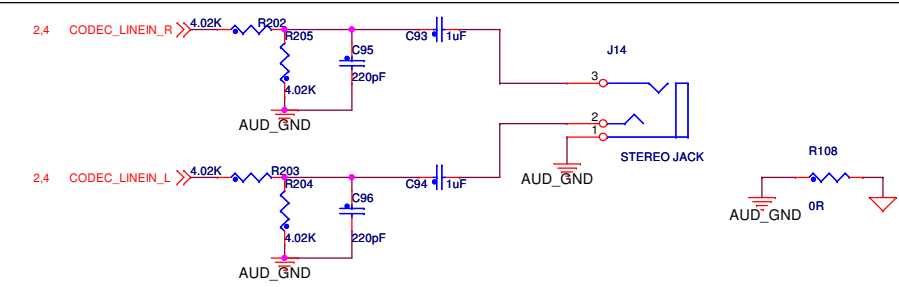

RS-232 TRX

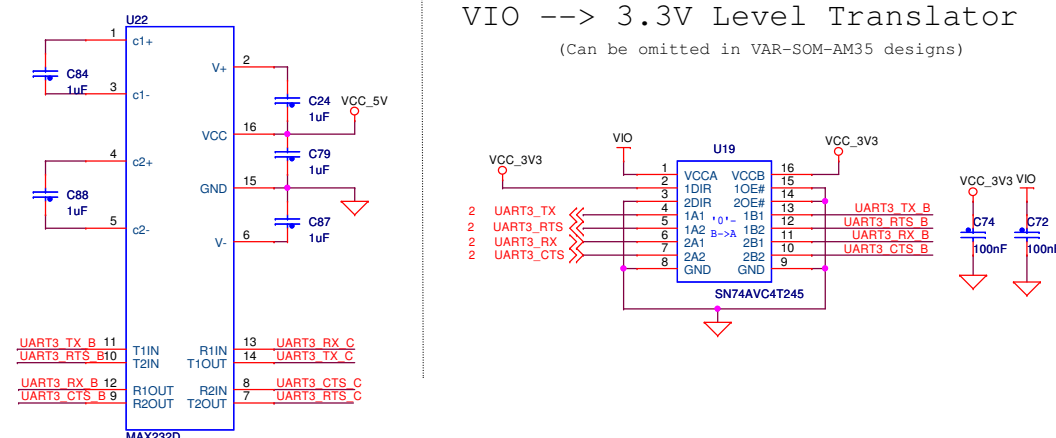

AUDIO OUT

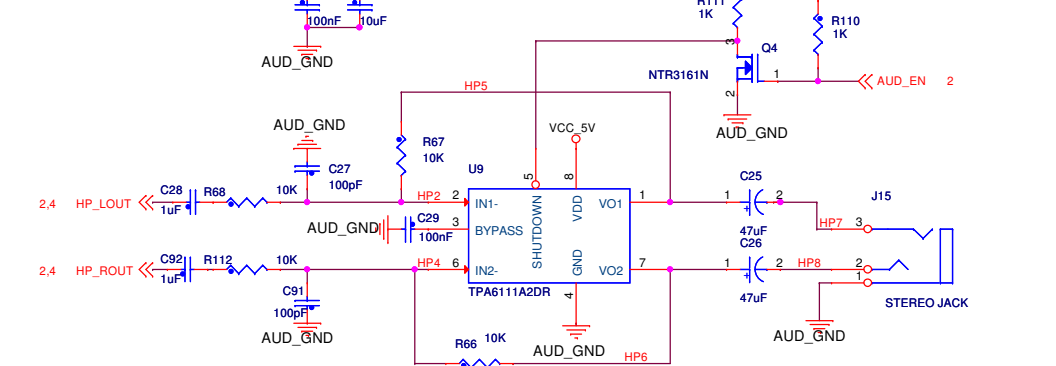

SD-Card

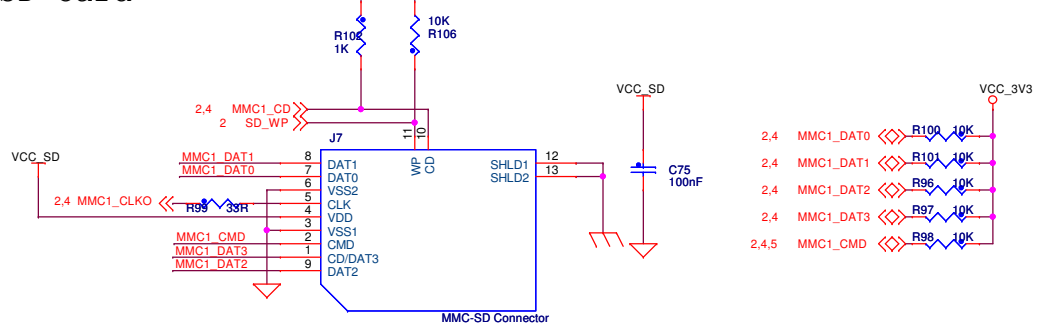

Debug Connector

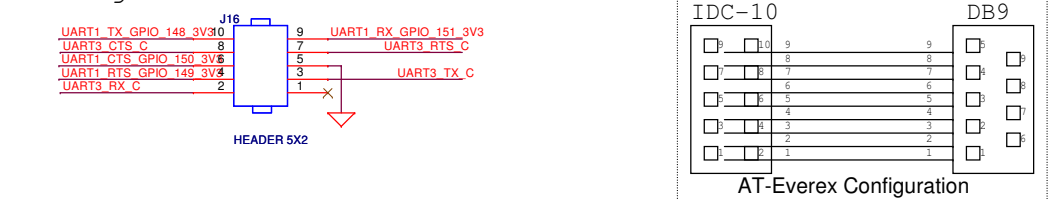

GPIO/UART1 VIO <--> 3.3V Level Translator

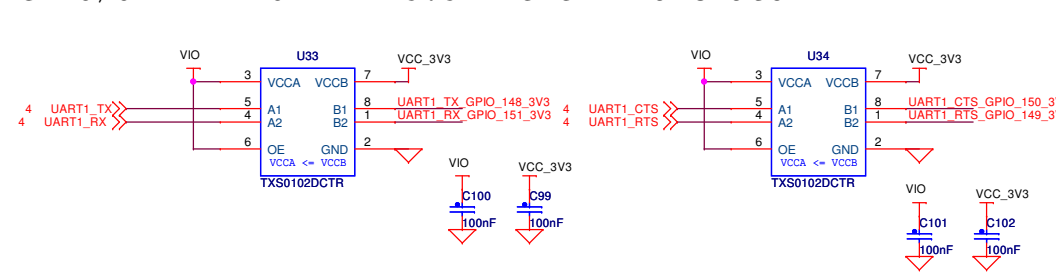

SD / MMC ESD protection

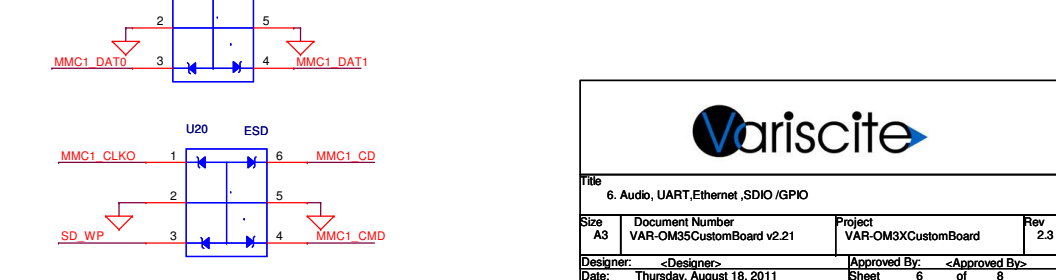

Title 6. Audio, UART, Ethernet, SDIO / GPIO			
Size A3	Document Number VAR-OM35CustomBoard v2.21	Project VAR-OM3XCustomBoard	Rev 2.3
Designer: Date: Thursday, August 18, 2011		Approved By: Sheet 6 of 8	

07 - Extension Connectors

Mechanics

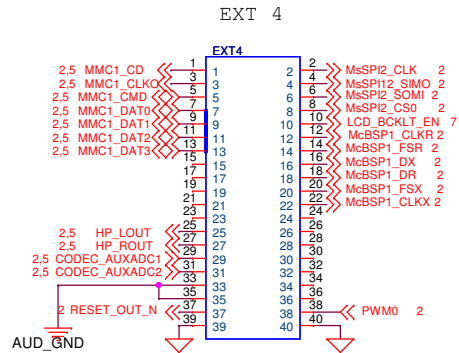
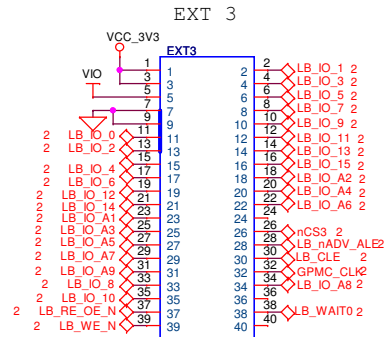
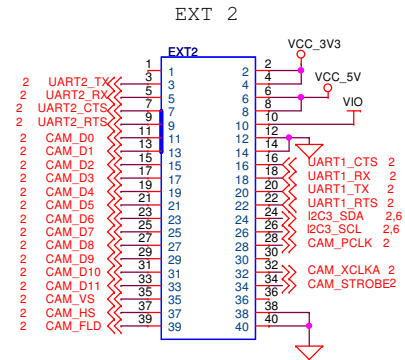
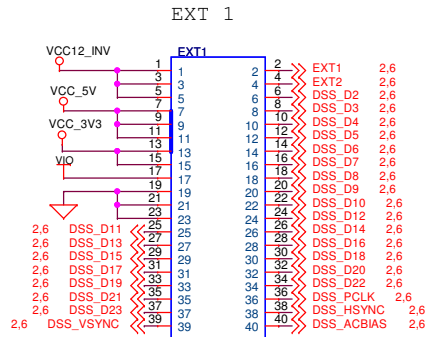



Title 7 - Extension Connectors			
Size A3	Document Number VAR-OM35CustomBoard v2.21	Project VAR-OM3XCustomBoard	Rev 2.3
Designer: <Designer>		Approved By: <Approved By>	
Date: Thursday, August 18, 2011		Sheet 7 of 8	

8. Power

Power In

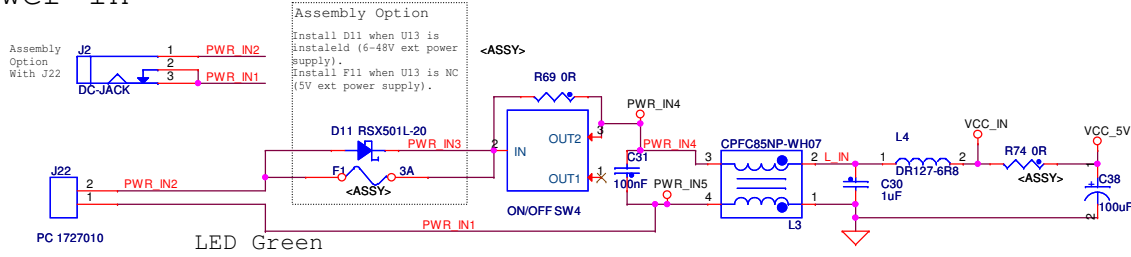

3.3v regulator

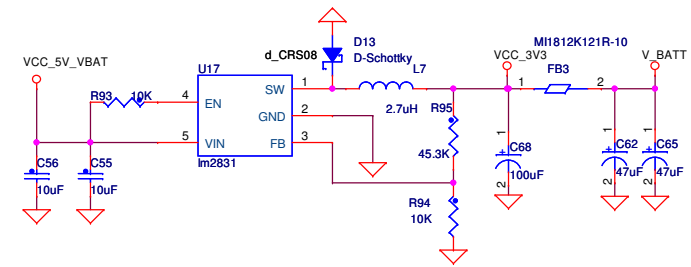

Main Power LED

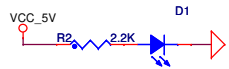

6-48v input regulator

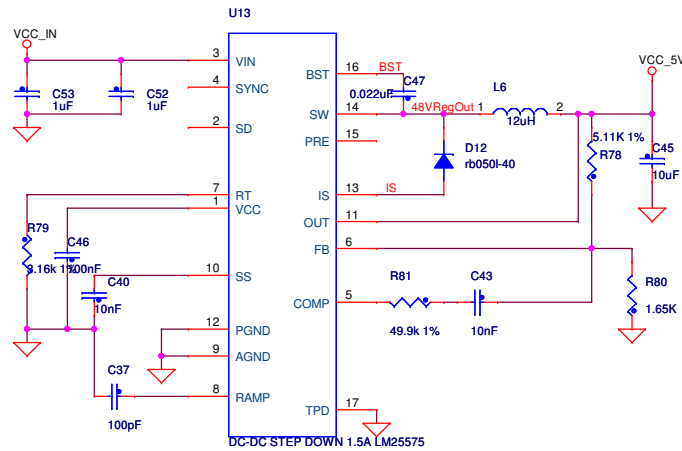

SD card & LCD power supply

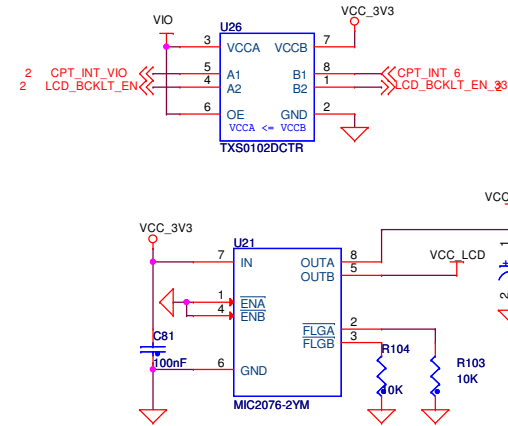

RTC Backup Battery

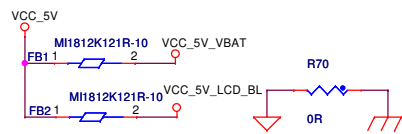
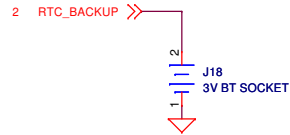

0.5A 12V Regulator for CCFL inverter

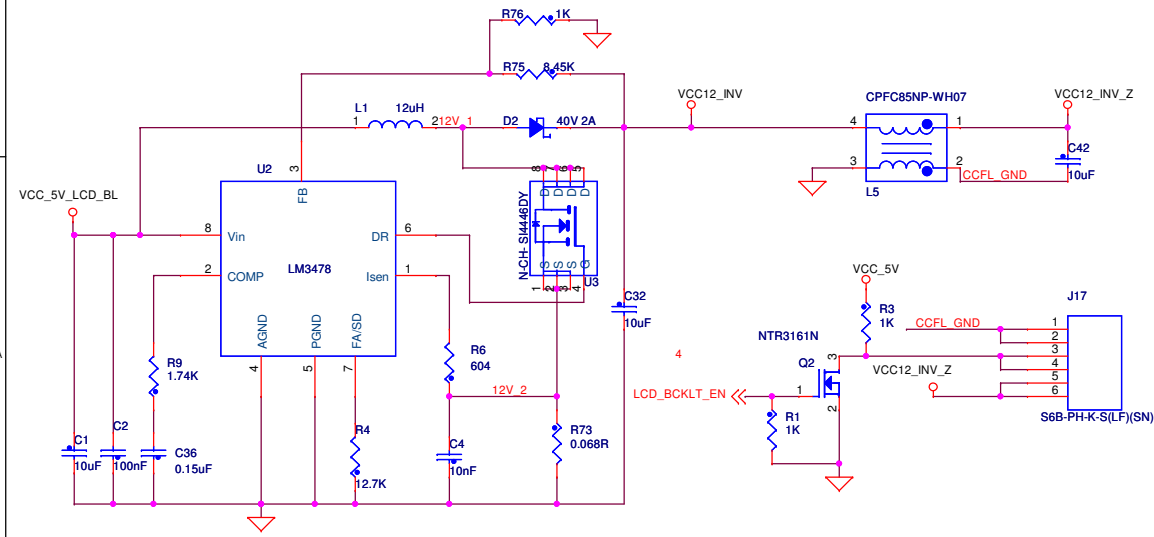

User button

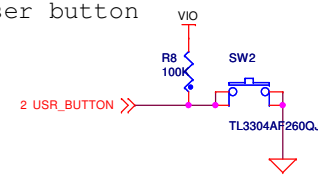

Hard - Reset button

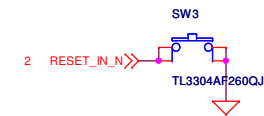

Sys-boot select button

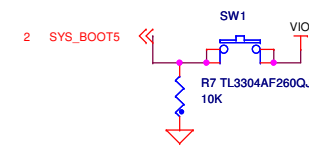

Title 8. Power			
Size A3	Document Number VAR-OM35CustomBoard v2.21	Project VAR-OM3XCustomBoard	Rev 2.3
Designer: Date: Thursday, August 18, 2011		Approved By: Sheet 8 of 8	